

Profi Liner 4 sliding roof double deck

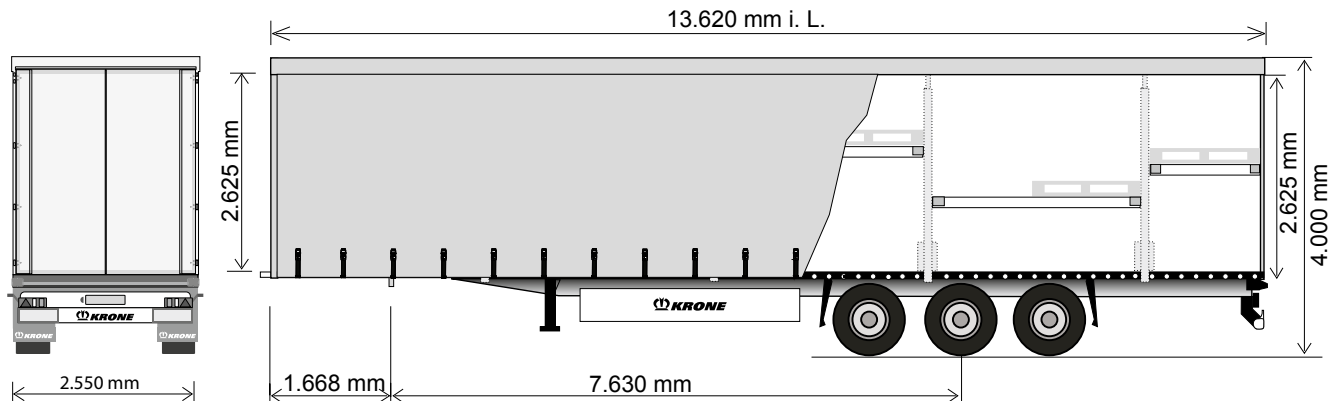

Technical data:	
Type:	SDP 27 eLB4-DS
King pin load:	12,000 kg
Axle load (technically possible):	27,000 kg
Allowable gross weight (technically possible):	39,000 kg
Tare weight:	approx. 6,760 kg
Payload (technically possible):	approx. 32,240 kg
Axle spread:	1,310 / 1,310 mm
Neck height:	125 mm
5th wheel height:	1,150 mm
Side access length:	13,620 mm
Side access height:	2,625 mm
Side access width:	2,480 mm
Turning radius:	2,040 mm

(Dimensions and weights for standard units)

Multi Lock side rave as standard:

Award winning Multi Lock side rave including load securing positions every 100 mm. Load securing even diagonally to the driving direction with more than 3000 strapping positions. Cost-effective and with best benefit.

No matter which loads should be transported, with the new Multi Lock- / Multi Blocksyste the loads are perfectly secured.

Technical description:	
Multi Lock side rave including load securing positions every 100 mm	Alloy cant rail, continuous, for support of sliding curtain and posts, EDSCHA sliding roof, height 125 mm, Roof also movable to the front and rear; diagonal roof spanning
2 mechanically operated landing legs, 2 x 12 tonnes capacity, half round compensating feet	Front wall bolted with solid corner posts; lateral restricted through loading; Front wall reinforced with plywood inner skin; quick release for side curtains on front wall
Low-maintenance axles with air suspension and disc brakes (430 mm); raise/lower valve incl. auto reset valve; Rims centre nave	Steel container rear doors including bolted steel frame, integrated door looks and concealed door hinges; roof header hinged and movable
Tyres: 6 x 385/65 R 22.5, brand: Krone choice	5 pairs of side posts, moveable, lateral lockings from 750–1,950mm on top of floor level (in 100 mm steps), for fixing and height adjustment of double deck side bars, (5 x approx. 2,280 mm and 1 x approx. 1,076 mm), plank pocket set on floor level
Wheel covering according to EC-regulations; Spray suppression according to EC-guidelines	12 side double deck bars, integrated lock rail for side to side double deck bars, 23 side to side double deck bars, lockable into side; capacity per bar: approximately 480 kg, total capacity of second level up to approximately 10,560 kg divided over total loading length, capacity per pallet position : 320 kg
spare wheel carrier as an option	Delta shaped rubber profiles at rear; delta steel buffers at rear; load security certificate according EN 12642 Code XL
EC braking system including vehicle stabilising system; low-maintenance automatic; spring-loaded hand brake; 2S/2M EBS system, 2 sensors on each axle with RSS, diagnostics on ISO 7638 socket (EBS)	1 PVC curtain with full lengths vertical reinforcements, top with rollers for sliding curtains, bottom with tensioners, curtain tensioner out of stainless steel
24 volts lighting system with 2 x 7-pin socket DIN ISO 1185/3731; front and rear marker lights; with two multi-function rear lights acc. to EC incl. rear fog light and reversing lights; 2 contouring lights with rubber arm in LED; side marker lights in LED	Steel parts shot blasted, with KTL primer and high-quality surface coating (standard painting single-colour); axles incl. wheel hubs painted black; underrun protection and light panel powder coated white for safety reasons; wheels silver with high-quality paint finish; reflective outline marking according to ECE-R48
30 mm thick, phenolic coated plywood floor, cut surfaces fully waterproofed and sealed. Strength acc.to DIN 283; for floor loadings up to 7,000 kg stacker-truck axle load	

Certified and especially safeguarded: The Profi Liner with double deck



The double deck includes 12 side double bars with an integrated lock rail for side to side. 23 side to side double deck bars are included. This results 33 pallet storage spaces in the second level with the capacity of max. 320 kg per pallet.

With a constant setting, a loading up to 10.560 kg in the second level is possible.

The handling is comfortable and easy: within the integrated lock rail the side double bars will be fixed. The side double bars and also side to side double deck bars secures itself and will be fixed.



The bars could be adjusted in 100mm steps, from 750-1950mm above the floor.



The double deck bars can also be used for the security during the start-up process.



5 pairs of side posts split the platform in 6 fields (5x approx. 2.280 mm and 1 approx. 1.076mm, at the back). In case of non-use, the double deck bars can also be used as "planks" and be stored alongside between the side posts.